



FM Approved Remote Kit Assembly

Owner's Manual

GENERAL INFORMATION

This Remote Kit Assembly allows FLOMEC® turbine meters to be used in a wide range of specialized environments. It enables isolation of the flow sensor from the digital readout. It can be used to measure high and low temperature fluids.

NOTE: To maintain the Factory Mutual Approval of this kit it must be installed in accordance with instructions given in this manual. It must also be used with a FLOMEC Factory Mutual Approved meter. When installation is complete the Factory Mutual decal should appear on the turbine, sensor and dustcover.

Installation should be in accordance with ANSI/ISA RP12.6 "Installation of Intrinsically Safe Systems for Hazardous (Classified) Locations" and the National Electrical Code (ANSI/NFPA 70).

Purpose of this Manual

⚠ CAUTION

Follow the facility's recommended practice for installation of equipment in hazardous locations.

This manual will assist you in installing, operating, and maintaining your Remote Kit Assembly. It gives information which will help you achieve years of dependable performance and trouble-free operation.

This manual provides information for the FLOMEC Remote Kit Assembly. Please refer to the appropriate owner's manuals for instructions on the use and maintenance of meters or other equipment.

Please take a few moments to read through this manual before installing and operating your kit. If you need assistance, please contact the dealer from whom you purchased your kit or the factory.

Read Me!

Use caution when handling hazardous substances or working in potentially dangerous environments. Follow appropriate safety practices and manufacturer's recommendations.

Damage Inspection

Upon receipt of your kit, inspect all parts and components. If any items are damaged or missing, please contact your dealer or distributor. Please note that this kit is a meter accessory and does not include the meter itself.

Use the following instructions to install the Remote Kit Assembly to a FLOMEC meter.

INSTALLATION

You will need the following tools for installation:

- Small Phillips screwdriver
- Drill with a drill bit for bolt or screw size intended to be used for mounting the dust cover (see below).
- Wire stripper
- Wire cutter
- Wire crimper
- Jig Saw or similar
- Electrical tape

Mounting Preparation

Before installing the Remote Kit, consider the mounting of the meter's computer and dust cover carefully. Select the location for mounting the computer. Using the provided template, make sure the dust cover will fit in the desired location.

Check the route of the cable from the sensor to the computer. Ten feet (3 m) of cable is provided with the kit. If a longer cable is required, make sure it does not exceed the maximum recommended length of 100 feet (30.5 m).

NOTE: To retain Factory Mutual Approval of this kit, use only Belden Cable #9501, 2 wire shielded.

If more than 10 feet of cable is needed, remove the old cable by loosening the strain relief and terminal block connections on the sensor. Connect the new cable in similar manner.

A template is supplied with the remote kit to aid in installing the dust cover. Position the template in the desired location and cut the hole. Drill the screw holes at each corner using a drill bit sized for the bolt or screw you intend to use. The dust cover holes will accommodate a #10 (3/16 in.) bolt or screw.

Prepare the meter for installation of the Remote Kit by removing the four screws from the corners of the computer's face. Gently separate the computer from the turbine. Disconnect the 2-pin terminal housing connector from the turbine to the computer back. Your sensor will connect to the turbine and the computer will connect to the dust cover in the same manner.



This Remote Kit Assembly is Factory Mutual Approved for Intrinsically Safe Class I, II, III, Division 1, Groups ABCDEFG and Nonincendive for Class I, II, III, Division 2, Groups ABCD FG.

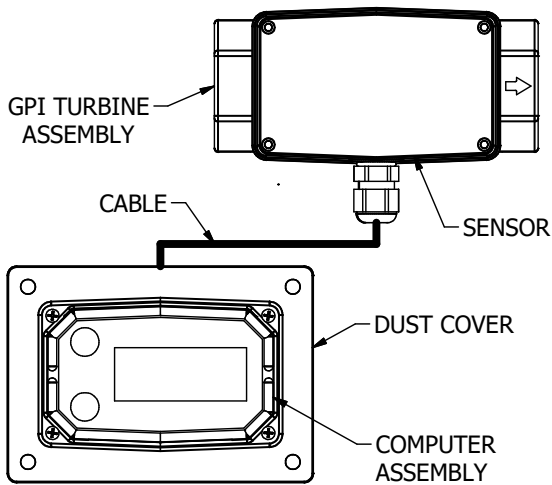

Mounting the Sensor and Turbine

1. Using the four screws provided, mount the sensor to the turbine. Use the long, course thread screws, identified as Item 6B on the Illustrated Parts List, to mount the sensor to a plastic turbine. Use the fine thread metal screws, 6A to mount the sensor to a metal turbine.

NOTE: To retain Factory Mutual Approval, a Factory Mutual Approved turbine must be used.

2. Install the turbine in the flow path. Wrap all threads with 3 to 4 turns of Teflon® tape. Make sure the tape does not impair the flow path. Hand tighten the turbine to the fittings. Use of a wrench could damage the turbine.
3. Route the cable from the sensor to the dustcover location and, allowing an extra 5 to 8 inches (12 to 20cm), cut it to length.
4. Prepare the end of the cable for connection to the dust-cover by stripping 1-1/2 inches (4cm) of outer insulation. Strip an additional 1/4 inch (0.5cm) of inner insulation from each wire. Crimp the solderless ring terminals, identified as Item 3 in the Illustrated Parts List, to the ends.

Mounting the Computer and Dust cover

1. Connect the cable to the dust cover by loosening the lower nuts, identified as Item 5 on the Illustrated Parts List, and slipping on the ring terminals. Tighten the nuts.
2. Insert the dust cover into the cutout and attach with the intended bolts or screws provided by user.
3. Insert the 2-pin terminal housing connector from the dust cover into the mating socket on the back of the computer.
4. Make sure the foam pad is positioned correctly and that the batteries and 2-pin terminal housing connector are securely connected.
5. Attach the computer assembly onto the dust cover using the short, course thread screws, identified as Item 4 on the Illustrated Parts List.

OPERATION / MAINTENANCE

During daily use, FLOMEC® meters and the Remote Kit Assembly are maintenance-free. It is important, however, that the turbine's rotor moves freely. Refer to the meter owner's manual or other instructions on use, maintenance, and calibration. Remote Kit Assembly installation should not affect meter calibration.

NOTE: To maintain Factory Mutual Approval, you must use batteries from the list of approved batteries below:

Alkaline (AAA size, 1.5-volts each)
 Energizer®, Alkaline, E92 or En92
 Duracell®, Alkaline, Mn2400

TROUBLESHOOTING

READOUT ON, BUT NOT COUNTING.

1. **Cable too long.** Shorten cable to 100 feet or less.
2. **Wiring broken or not connected.** Inspect all wires and connections. Repair or connect as necessary.

NOTE: Please refer to the appropriate owner's manual for troubleshooting of meters and other equipment.

ILLUSTRATED PARTS DRAWING

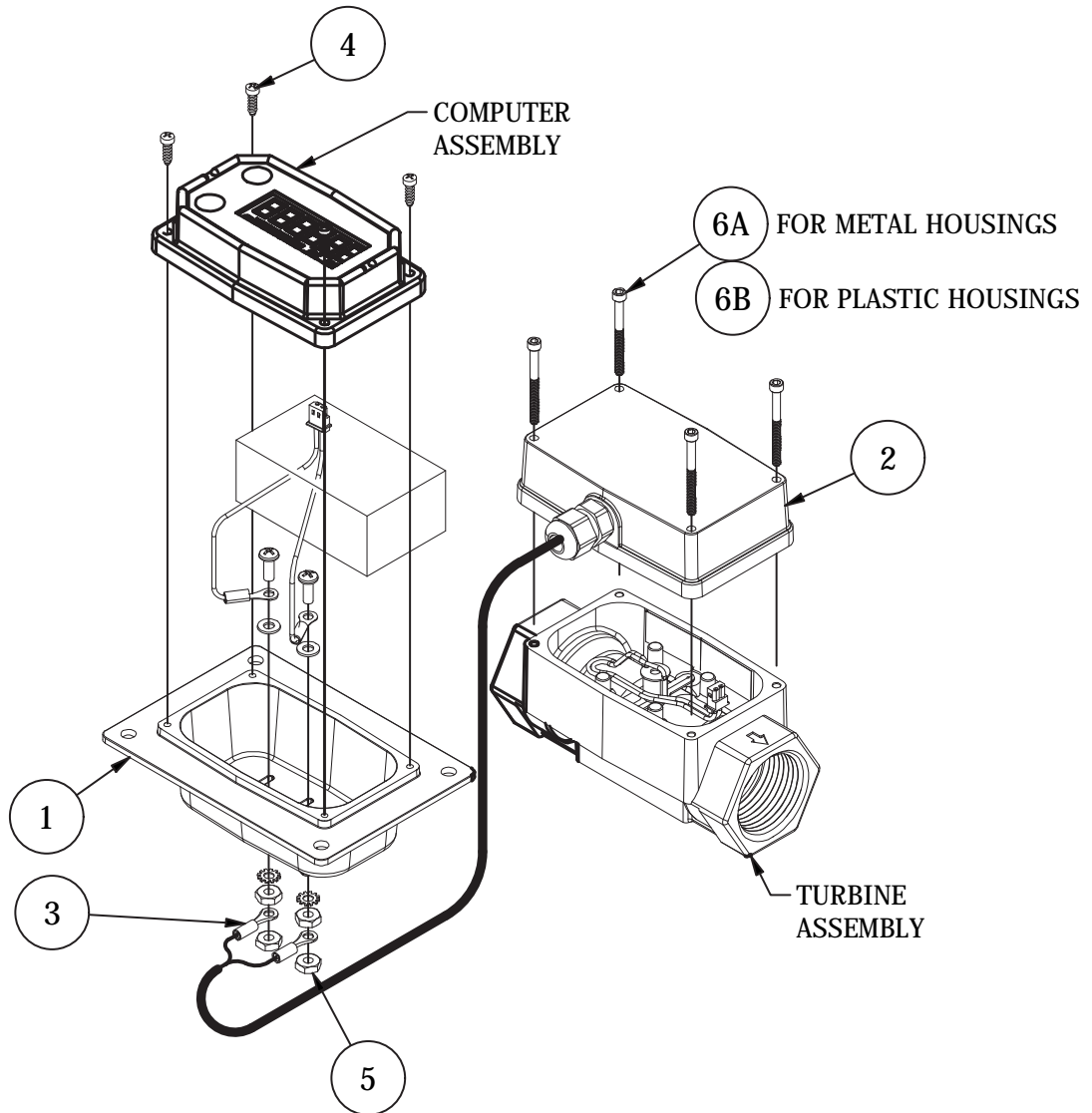

ITEM NO.	PART NO.	DESCRIPTION	NO. REQ'D
1	113264-20	ASSEMBLY, DUST COVER (GEN 2)	1
2	113273-10	ASSEMBLY, SENSOR MODULE (GEN 2) W/10 FT. CABLE	1
3	902004-51	TERMINAL, RING	2
4	904003-21	TAPPING SCREW, 4-20 X 3/8", CR FILL HD, SS	4
5	904004-50	HEX NUT (#6)	2
6A	904009-64	SCREW, SHCS, 4-40 X 1.250, SS	4
6B	904009-65	SCREW (3 X 35MM) PAN HD, SS	4

SPECIFICATIONS

Dustcover:	Molded plastic with terminal block connection
Sensor:	Molded nylon 6/6 housing
Magnetic Pickoff:	1.3 k Ohm, 90 mH
Cable:	10 ft. (3m), 2-conductor shielded, Belden #9501
Transmission Distance:	Up to 100 ft. (30.5m)
Signal Type:	Sine Wave
Peak to Peak Voltage:	10 to 500 mV
Frequency:	11 to 608 Hz
Fluid Temp. Range:	-40°F to +250°F (maximum depending on turbine limitations) -40°C to +121°C (maximum depending on turbine limitations)
Operational Range:	+14°F to +140°F -10°C to +60°C

SERVICE

For warranty consideration, parts, or other service information, please contact your local distributor. If you need further assistance, contact the GPI Customer Service Department in Wichita, Kansas, during normal business hours.

Tel: 316-686-7361
Fax: 316-686-6746
Toll free: 1-888-996-3837

To obtain prompt, efficient service, always be prepared with the manufacturing date code, found behind the coverplate.

For warranty work, always be prepared with your original sales slip or other evidence of purchase date.

Please contact GPI before returning any part. It may be possible to diagnose the trouble and find a solution with a telephone call. GPI can also inform you of any special requirements you will need to follow for shipping.

Limited Warranty Policy

Great Plains Industries, Inc. 5252 E. 36th Street North, Wichita, KS USA 67220-3205, hereby provides a limited warranty against defects in material and workmanship on all products manufactured by Great Plains Industries, Inc. This product includes a 2 year warranty from date of purchase as evidenced by the original sales receipt. A 30 month warranty from product date of manufacture will apply in cases where the original sales receipt is not available. Reference product labeling for the warranty expiration date based on 30 months from date of manufacture. Manufacturer's sole obligation under the foregoing warranties will be limited to either, at Manufacturer's option, replacing or repairing defective Goods (subject to limitations hereinafter provided) or refunding the purchase price for such Goods theretofore paid by the Buyer, and Buyer's exclusive remedy for breach of any such warranties will be enforcement of such obligations of Manufacturer. The warranty shall extend to the purchaser of this product and to any person to whom such product is transferred during the warranty period.

This warranty shall not apply if:

- A. the product has been altered or modified outside the warrantor's duly appointed representative;
- B. the product has been subjected to neglect, misuse, abuse or damage or has been installed or operated other than in accordance with the manufacturer's operating instructions.

To make a claim against this warranty, contact the GPI Customer Service Department at 316-686-7361 or 800-835-0113. Or by mail at:

Great Plains Industries, Inc.
5252 E. 36th St. North
Wichita, KS, USA 67220-3205

GPI will step you through a product troubleshooting process to determine appropriate corrective actions.

GREAT PLAINS INDUSTRIES, INC., EXCLUDES LIABILITY UNDER THIS WARRANTY FOR DIRECT, INDIRECT, INCIDENTAL AND CONSEQUENTIAL DAMAGES INCURRED IN THE USE OR LOSS OF USE OF THE PRODUCT WARRANTED HEREUNDER.

The company herewith expressly disclaims any warranty of merchantability or fitness for any particular purpose other than for which it was designed.

This warranty gives you specific rights and you may also have other rights which vary from U.S. state to U.S. state.

Note: In compliance with MAGNUSON MOSS CONSUMER WARRANTY ACT – Part 702 (governs the resale availability of the warranty terms).

Wichita · Sydney

GREAT PLAINS INDUSTRIES 

© 2020 Great Plains Industries, Inc., All Rights Reserved.

Great Plains Industries, Inc. / 888-996-3837 / FLOMECmeters.com